

**COPPER BRACKET
FLAT LAYOUT**

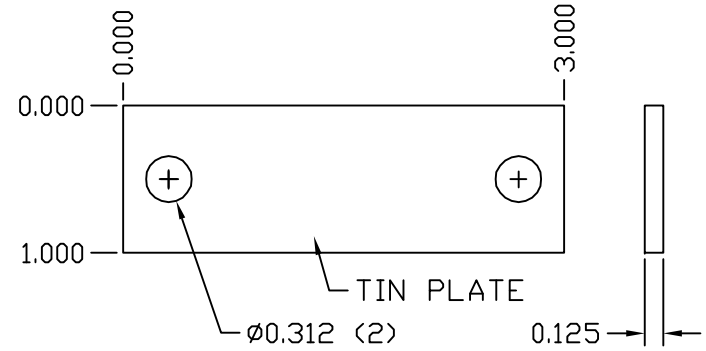

COPPER SANDWICH PLATE

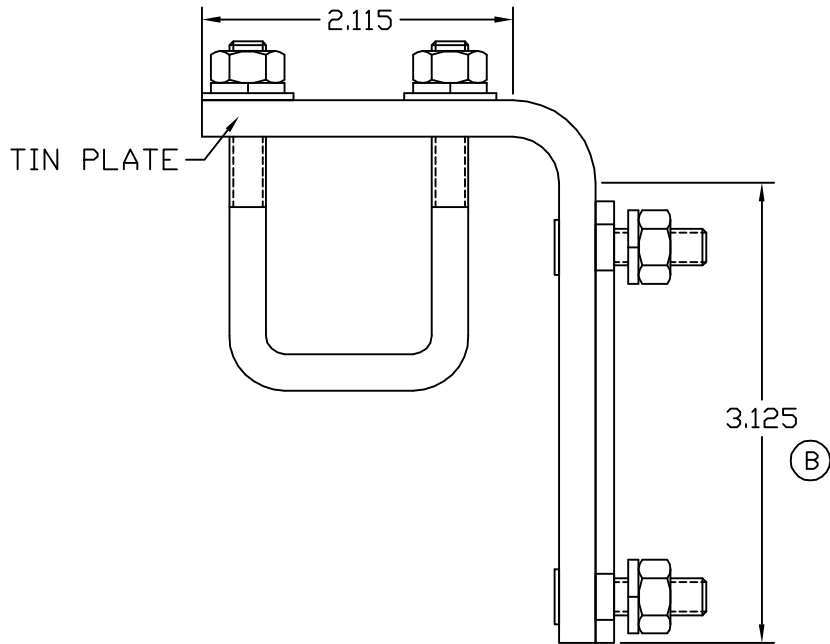

GROUND PEDESTAL CLAMP

EST WT 0.8#

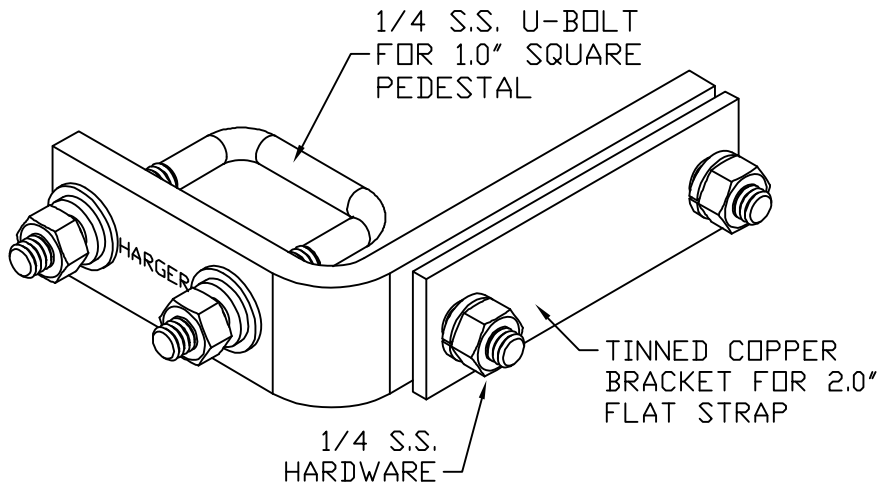

APPROVED

AS DRAWN: _____
 AS NOTED: _____
 DATE: _____

THIS DOCUMENT AND THE CONTENTS THEREOF IS THE PROPERTY OF HARGER INC., AND IS FURNISHED TO YOU FOR INFORMATION ONLY. THE INFORMATION CONTAINED HEREIN IS CONFIDENTIAL AND OF A PROPRIETARY NATURE AND MUST NOT BE DISCLOSED TO THIRD PARTIES WITHOUT THE EXPRESS WRITTEN APPROVAL OF HARGER INC.

B	WAS 3.00	072503	LAL
A	ADDED PACKAGING NOTE	052703	EHS
LET	REVISION	DATE	BY
TOLERANCES UNLESS NOTED:		3RD ANGLE PROJECTION	
FRACTIONAL +/- 1/16			
DECIMAL +/- .030			
BREAK SHARP EDGES			

PART NO. GPC2FSSQ
 GROUND PEDESTAL CLAMP

DRAWN BY:
LAL
 CHECKED BY:
 DATE:
 050503



301 ZIEGLER DRIVE
 GRAYSLAKE, IL 60030
 (847) 548-8700

REVISION:
B
 SCALE:
3/4
 SHEET:
1 OF 1