

(A)

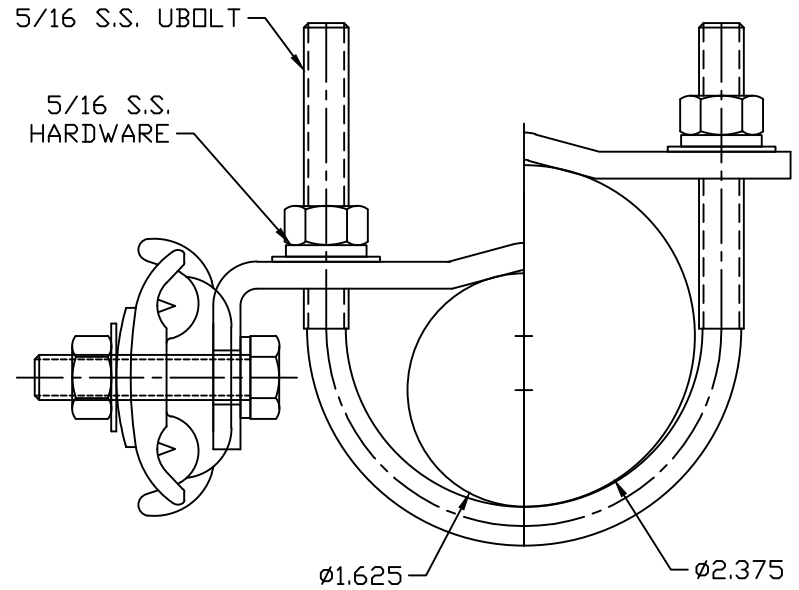
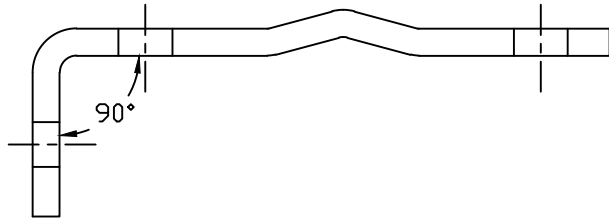

**S.S. PIPE CLAMP**

EST WT 1#

**APPROVED**

AS DRAWN: \_\_\_\_\_  
 AS NOTED: \_\_\_\_\_  
 DATE: \_\_\_\_\_

THIS DOCUMENT AND THE CONTENTS THEREOF IS THE PROPERTY OF HARGER INC., AND IS FURNISHED TO YOU FOR INFORMATION ONLY. THE INFORMATION CONTAINED HEREIN IS CONFIDENTIAL AND OF A PROPRIETARY NATURE AND MUST NOT BE DISCLOSED TO THIRD PARTIES WITHOUT THE EXPRESS WRITTEN APPROVAL OF HARGER INC.

A	WAS 12GA MAT'L	091704	LAL
LET	REVISION	DATE	BY
TOLERANCES UNLESS NOTED:		3RD ANGLE PROJECTION	
FRACTIONAL	+/- 1/16		
DECIMAL	+/- .030		
BREAK SHARP EDGES			

**PART NO. SSGC1.625/2.3750D**  
 PIPE CLAMP

DRAWN BY:  
**LAL**  
 CHECKED BY:  
 DATE:  
 070604

**HARGER**  
 301 ZIEGLER DRIVE  
 GRAYSLAKE, IL 60030  
 (847) 548-8700

REVISION:  
 A  
 SCALE:  
 3/4  
 SHEET:  
 1 OF 1